

PROCESS SENSORS

C O R P O R A T I O N



PSC PI **infrared online camera**

Industrial Thermal Imaging Camera

Ethernet, USB or fiber optic connection

-20 to 900°C measurement temperature range

Up to 100 Hz real time video recording

Very small, water proof and rugged camera head with exchangeable lenses

Connected via up to 10 km extendable USB 2.0 interface

Accessories for adaption to a wide range of industrial and scientific applications

Extensive Windows based software package

Closing the gap between handheld infrared snapshot cameras and pure online installations

Thermal processes in the industry

Next to time, temperature is the most frequently measured physical property. The temperature behavior is therefore a very good indicator for the status of physical systems. Too much friction generates heat, too high resistance of electrical contacts creates higher temperatures; energy losses are mostly shown by changes in temperature. Therefore one can find thermal processes in almost all industry branches.

Applications

With the PSC PI you can not only see where it is hot, you can also measure exactly the temperatures, all within a 10 millisecond interval!

It provides excellent infrared images in a wide temperature range of -20 up to 900°C and an extensive range of software features to capture and edit infrared snapshots and videos, for thermal analysis with hot and cold spot detection display of isotherms and much more.

The PSC PI is the thermographic solution for:

- Research and Development (R&D)
- Test stations (T&M)
- Process automation
- Portable measurement tasks

Similar to an oscilloscope the infrared camera became an essential tool for engineers. The PSC PI can, for example, be used in the field of research and development for the observation of the thermal behavior of working PCBs during test runs. The camera offers a versatile use in test booths or at test stations due to its compactness. Inside test stations for breaks and clutches engineers will see thermal effects on the mechanical parts completely. In branches like the solar panel industry, in the development of LCD flat screens or in semiconductor process applications, the camera is qualified for material homogeneity identification. In the representation of finest temperature details at different targets, the camera distinguishes itself in priority through its very good thermal sensitivity (NETD 0.08 K with 31° FOV). In the application field of medical investigations the PSC PI allows accurate and reliable medical screenings in combination with an electronically controlled reference temperature device.

Within the range of process automation, the PSC PI is a reliable monitoring system for the observation of continuous processes within the plastic industry, flat glass production, metal treatment and surface technology. Hotspots within bulky materials on conveyor belts can be detected

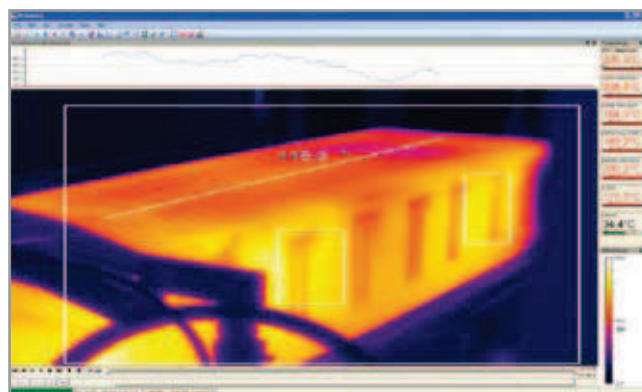
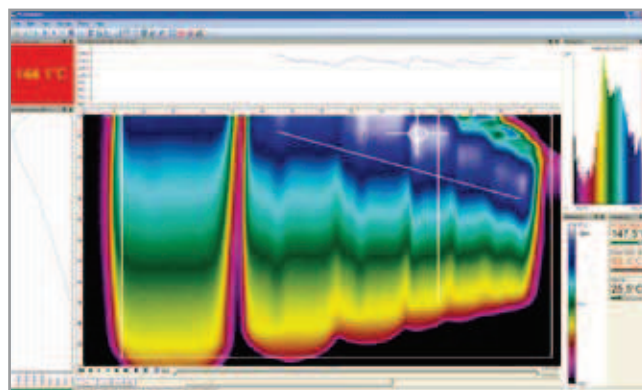

quickly to avoid the development of fire. Network integration tools help to implement the PSC PI into factory automation systems. The optional cooling jacket and other accessories allow the installation under harsh environments. The PSC PI can be combined with pyrometers and blackbody reference sources for smart and reliable temperature observations under difficult ambient conditions.

A process interface output with an analog 0-10V or an alarm signal is the direct communication interface to the process. With this interface, temperatures of the main measuring area can be issued analogue or with an alarm. A process interface input allows beside the synchronization of the camera an external control of emissivity values, background radiation compensation or the triggering of video or snapshot recordings.

In combination with tablet PCs the PSC PI infrared camera can be used for preventive, electrical maintenance purposes as well as within the building thermography. Herewith the camera is closing the gap between handheld infrared snapshot cameras and pure online installations.

PSC PI The most portable infrared online camera

PI connect – The Videomaker

This real time software sets new standards with its variability and operability. The software **PI connect** offers extensive opportunities to the user:

- Video recordings and snapshots with up to 100 Hz
- Digital real time temperature data correction for all pixels
- Hot and cold spot analysis
- Editing of captured infrared video for reports and presentations

The user of the software can combine flexible spots with crosshair marking and programmable measurement areas with an automatic display of maximum-, minimum- or average temperature readings.

The use of the camera as a line scanner is supported by a set of scanner functions for the display of different temperature profiles alongside defined lines in separate graphs.

PI connect allows a self-explanatory recording of radiometric videos or snapshots as well as its analysis and post processing. The software also enables the complete parameterization and remote control of the infrared camera. **PI connect** opens a wide range of options to the user due to its eleven different color pallets, ready to use measurement and display layouts as well as video editing functions. To assure the technical actuality

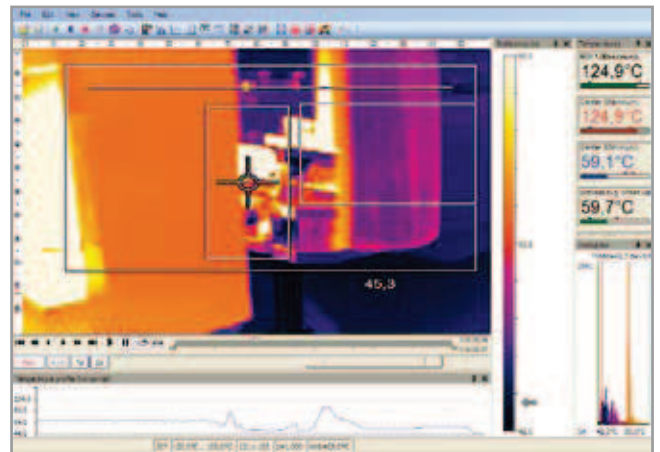

of the software, Process Sensors offers regular updates on its website. The development of customer specific software is supported through the preparation of comprehensive DLLs.

The software is capable to run on all kinds of netbooks, notebooks and PC systems covering Windows XP, Windows Vista and Windows 7 and does not require any additional driver installations.

Exchangeable lenses

The PSC PI has a very small, waterproof and rugged camera sensing head with exchangeable lenses of 31°, 9° and 64° field of view and an excellent radial distortion correction especially for the wide angle lenses.

Lens	Focal distance	Minimum distance		0,02	0,1	0,3	0,5	1,2	2	4	6	10	30	100
31° x 23° Standard-lens	10 mm	0.02 m	HFOV [m]	0,01	0,05	0,16	0,27	0,67	1,1	2,2	3,4	5,6	16,8	56,0
			VFOV [m]	0,00	0,04	0,12	0,21	0,50	0,8	1,7	2,5	4,2	12,6	42,0
			IFOV [mm]	0,04	0,3	1,0	1,7	4,2	7	14	21	35	105	350
9° x 7° Tele-lens	35.5 mm	0.5 m	HFOV [m]			0,04	0,07	0,18	0,31	0,6	0,9	1,6	4,7	15,8
			VFOV [m]			0,03	0,05	0,14	0,23	0,5	0,7	1,2	3,5	11,8
			IFOV [mm]			0,3	0,5	1	2	4	6	10	30	99
64° x 48° Wide-angle-lens	4.5 mm	0.02 m	HFOV [m]	0,02	0,12	0,37	0,6	1,5	2,5	5,0	7,5	12,5	37,5	125,0
			VFOV [m]	0,01	0,09	0,28	0,5	1,1	1,9	3,7	5,6	9,4	28,1	93,7
			IFOV [mm]	0,1	0,7	2	4	9	16	31	47	78	234	781

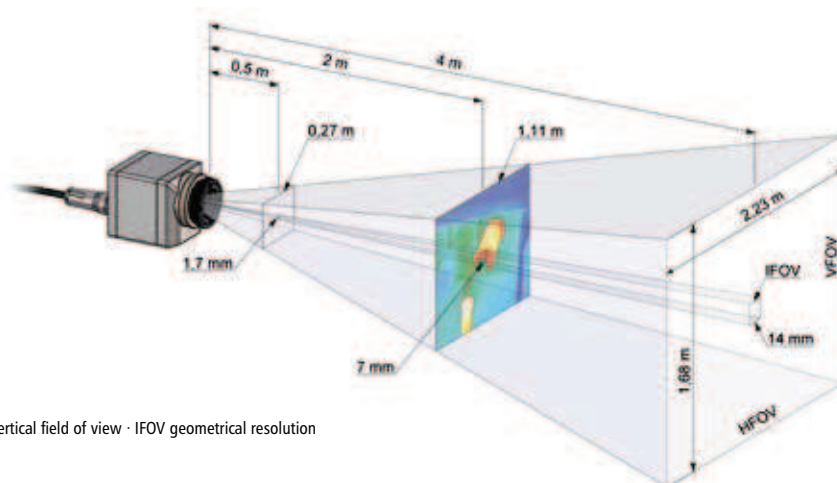

HFOV horizontal field of view · VFOV vertical field of view · IFOV geometrical resolution



Technical specifications

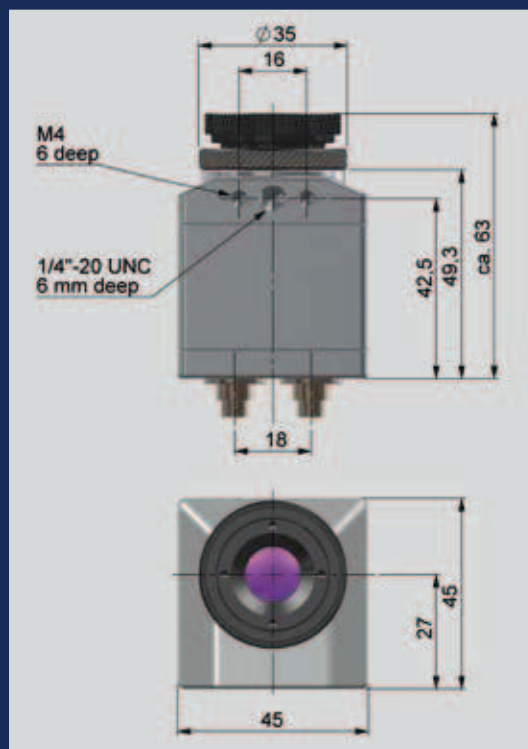

Scope of supply

PSC PI standard package

PSC PI (100 Hz, USB 2.0 interface), one lens, USB cable (1 m), table tripod, process interface connector, software package PI connect, operators manual, case

PSC PI thermal analysis kit

PSC PI (100 Hz, USB 2.0 interface), three lenses (31°, 9° and 64°, incl. calibration certificate), USB cable (1 m and 10 m), tripod (20-62 cm), process interface connector, software package PI connect, operators manual, aluminum case

General specifications	
Environmental rating	IP 67
Ambient temperature	0 - 50°C
Storage temperature	-40 - 70°C
Relative humidity	20 - 80 %, non condensing
Shock	25G, IEC 68-2-29
Vibration	2G, IEC 68-2-6
Weight	250 g, incl. Lens
Size	45 mm x 45 mm x 62 mm
Tripod mount	1/4-20 UNC
Output	USB 2.0
Power supply	USB powered
Process Interface (electrically isolated)	0-10V input, Digital input, 0-10V Output
Process Interface features	External control of emissivity, background radiation compensation or reference temperature/ Triggered video or snapshot recording/ Analog output of temperatures of main measuring area or alarm output
Warranty	2 years
Measurement specifications	
Temperature ranges	-20°C to 100°C 0°C to 250°C 150°C to 900°C
Frame rate	100 Hz
Lenses (exchangeable)	31° x 23° FOV/ f=10 mm 9° x 7° FOV/ f=36 mm 64° x 48° FOV/ f=5.7 mm
Thermal Sensitivity (NETD)	0,08 K with 31° FOV/ F=0.7 0,1 K with 64° FOV/ F=1 0,3 K with 9° FOV/ F=1.6
Detector	Focal Plane Array (FPA) uncooled micro bolometer 35 x 35 μm
Spectral range	7,5 - 13 μm
Optical resolution	160 x 120 pixel
System accuracy	±2% or ±2°C
Software features	
Configuration	Automatic or manual scaling of the measuring range/ Selectable and definable software layouts/ Language-translation-tool/ Adjustable measuring parameters (Emissivity 0.10 - 1.00, Background radiation compensation, Reference temperature)
Measurement Modes	Flexible spots and measurement fields with automatic calculation of MAX, MIN or AVG values/ Automatic HOT-spot- and COLD-spot-finder/ Temperature profiles/ Isotherm exposition/ Reference function (with external sensor), Linescanning modes
Image presentation	11 color palettes/ Color reference bar/ Histogram/ Digital display of measuring field temperatures (with alarm signal)/ Video control (play, pause, stop, detail screen forward and backward)/ Full screen mode
Video recording	Realtime video recording (radiometric) with 100 Hz (adjustable)/ Video editing tools/ Snapshot saving (radiometric JPG)